

Models

PP & PVDF:	stainless steel:
CTV 25-9	CTV 20-9
CTV 25-10	CTV 25-9.8
CTV 25-11	CTV 40-12.5
CTV 25-11.5	CTV 40-13.5
CTV 32-8.5	
CTV 32-10	
CTV 32-12.5	

CTV series

English



CE Instruction manual

vertical centrifugal pumps

topflo®

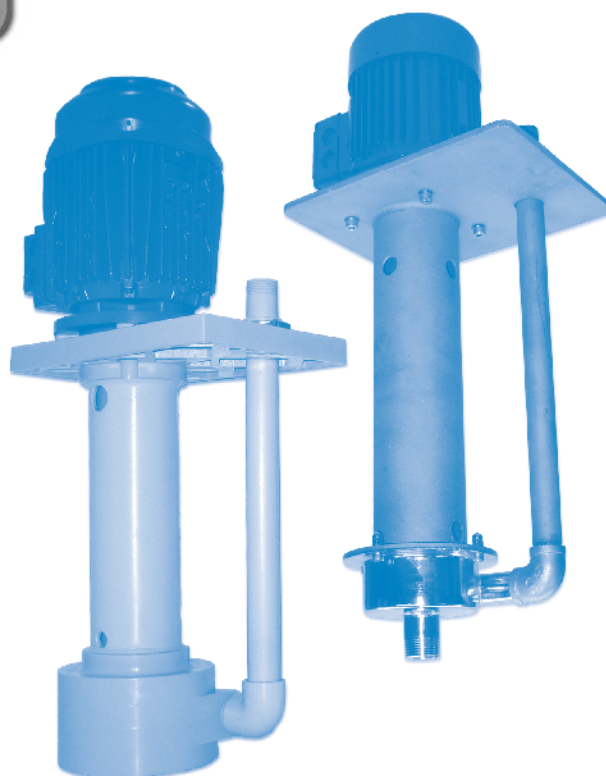

- ▶ Instructions for installation, start up, operation, maintenance and repair
- ▶ Spare parts



Read this instruction manual carefully, before you install and operate the pump

CONTENTS

Chapter	Content	Page
	CONTENTS	2
	CE CERTIFICATE	3
0.	GENERAL	4
0.1	Introduction	4
0.2	The warning symbols	4
0.3	Qualification and training of personnel	4
0.4	Description of the pump	5
0.5	General limits	5
0.6	Health & safety	6
1.	INSTALLATION	7
1.1	Receiving inspection	7
1.2	Storage	7
1.3	Installation	7
1.4	Piping	7
1.5	Installation example	8
1.6	Instruments	9
1.7	Motor Connection	9
2.	OPERATION	10
2.1.1	Starting the pump	10
2.1.2	Re-starting after power shutoff	10
2.2	Stopping the Pump	10
3.	MAINTENANCE	11
3.1	Maintenance schedule	11
3.2	Trouble shooting	11
3.3	Assembly and disassembly	12
3.3.1	Assembly drawings	12
3.3.2	Dismantling PP & PVDF pumps	13
3.3.3	Dismantling stainless steel pumps	13
3.3.4	Parts inspection	13
3.3.5	Assembly of the pump - PP, PVDF and stainless steel pumps	13
4.	SPARE PARTS	14
4.1	Spare parts CTV pumps in PP & PVDF	14
4.2	Spare parts CTV pumps in stainless steel	15
4.3	Stocking recommendation	16
4.4	Pump code	16
5.	DATA	17
5.1	Performance curves	17
5.1.1	Performance curves PP & PVDF pumps	17
5.1.2	Performance curves stainless steel pumps	17
5.2	Technical data	18
5.2.1	Data PP & PVDF pumps	18
5.2.2	Data stainless steel pumps	19
6.	WARRANTY & REPAIR	20
6.1	Returning parts	20
6.2	Warranty	20
6.3	Warranty form	22

Declaration of conformity

Machinery directive 2006/42/EC

Tapflo AB declares that:

Product name: **Vertical centrifugal pumps**
Models: **CTV...**

Is in conformity with the essential health and safety requirements and technical construction file requirements of the EC Machinery directive 2006/42/EC.

Manufacturer: **Tapflo AB**

Address: **Filaregatan 4
S-442 34 Kungälv
Sweden**

Tapflo AB, may 2:nd 2010



Håkan Ekstrand
Managing director

▶ 0. GENERAL

0.1 Introduction

CTV is a vertical, seal less centrifugal pump made from PP, PVDF or stainless steel AISI 316L. With proper attention to maintenance, CTV pumps will give efficient and trouble free operation. This instruction manual will familiarise operators with detailed information about installing, operating and maintaining the pump.

0.2 The warning symbols

The following warning symbols are present in this instruction manual. This is what they say.



This symbol stands next to all safety instructions in this instruction manual where danger to life and limb may occur. Observe these instructions and proceed with utmost caution in these situations. Inform also other users of all safety instructions. In addition to the instructions in this instruction manual, the general safety and accident prevention regulations must be observed.



This symbol signals possible danger caused by the presence of electric fields or live wires.



This signal stands at points in this instruction manual of particular importance for compliance with regulations and directives, for correct work flow and for the prevention of damage to and destruction of the complete pump or its subassemblies.

0.3 Qualification and training of personnel



The personnel in charge of installation, the operation cycle and maintenance of the pumps we produce must be qualified to carry out the operations described in this manual. Tapflo shall not be held responsible for the training level of personnel and for the fact that they are not fully aware of the contents of this manual.

0. GENERAL

0.4 Description of the pump

The CTV pumps are centrifugal, vertical, single-stage pumps with the pump casing directly submerged in the liquid. It is driven by a non-synchronous electric motor. The inlet is axial, facing downwards and has a BSP threaded connection. The discharge pipe is vertical, coming up through the base plate and has a BSP threaded connection (other connection types available upon request).

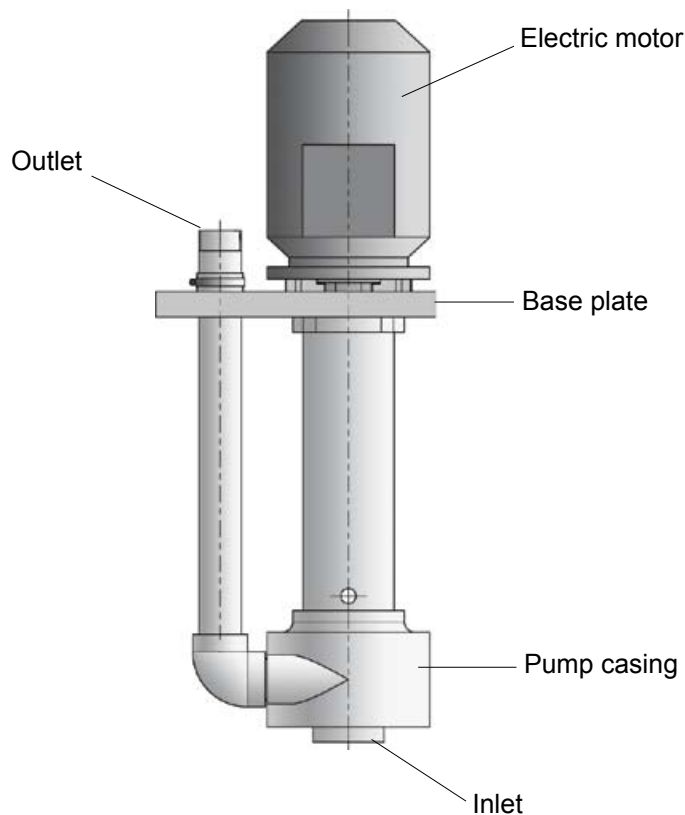

0.5 General limits

CTV pumps are made from polypropylene (PP), polyvinylidene fluoride (PVDF) or stainless steel AISI 316L.

Temperature

General limits based on water. With other chemicals the limits may be reduced, please consult us.

PP pumps:	70°C
PVDF pumps:	100°C
Stainless steel pumps:	100°C

Corrosion resistance

To determine the corrosion resistance of the different material options, the following information about the liquid is required:

- Chemical and concentration
- Temperature

Check our chemical resistance guide or consult us for selection of suitable material.

Solids

The CTV pumps are generally insensitive to solids, max size of solids is 6 mm.

Dry running

CTV pumps can run dry without damage.

▶ 0. GENERAL

0.6 Health & safety



Electric safety

Do not carry out any maintenance operation on the pump while it is running or before it has been disconnected from the power supply. Avoid any danger caused by electric power (for details see current regulations in force). Check that electrical specifications on the data plate are equivalent to the power supply to which it will be connected.



Chemical hazards

Avoid pumping liquids, even in different moments that may cause chemical reactions without having cleaned the pump.



Temperature hazards

The cold or hot parts of the machine must be protected to avoid accidental contacts.



Rotating parts

Do not tamper with the protection of the rotating parts, do not touch or approach rotating parts in movement.



Noise level

CTV pumps, including the motor, in normal operating conditions produce a sound level below 80 dB(A). The major sources of noise are: liquid turbulence in the plant, cavitation or any other abnormal operation that do not depend from the pump construction nor the pump manufacturer. The user must provide suitable protective means if the sources of noise could produce a harmful noise level for operators and for the environment (in compliance with current regulations).



Modifications and Spare parts

Any changes concerning the service of the pump as originally purchased, can be executed only after written approval from Tapflo.

It is recommended to use only genuine Tapflo spare parts and approved accessories. The use of non-original spare parts or non approved accessories will void warranty and removes any responsibility on our behalf for any damage caused to people or things.

▶ 1. INSTALLATION

1.1 Receiving inspection

Although precaution is taken by us when packing and shipping, we urge you to carefully check the shipment on receipt. Make sure that all parts and accessories listed on the packing list are accounted for. Immediately report any damage or shortage to the transport company and to us.

1.2 Storage



- If the equipment is to be stored prior to installation, place it in a clean location.
- Do not remove the protective covers from the suction and discharge, which have been fastened to keep pump internals free of debris.
- Store the pump on the motor fan cover in an upright position, or hang the pump from the cover plate.
- Make sure to clean the pump thoroughly before installation.

1.3 Installation



- CTV pumps must be installed vertically and can be used in sumps, tanks and similar containers.
- For a safe "outside tank" installation always consult us for arrangement of necessary modifications.
- Install the pump on a rigid support and fastened by the cover plate.

1.4 Piping



A pump is generally part of a piping system that can include a number of components such as valves, fittings, filters, expansion joints, instruments, etc. The way the piping is arranged and the positioning of the components has a great influence on operation and the operating life of the pump. The pump cannot be used as a support for the components connected to it.

The flow of liquid from the pump must be as even as possible. It is advisable to avoid any tight bends or drastic reductions of diameters that may cause flow resistance in the plant. In case of diameter reduction, it is advisable to use appropriate conical reductions.



Discharge pipe

If the discharge height is more than 2 meters, a check valve should be installed in the discharge line (see installation example, chapter 1.5)

Suction extension

Use of extension pipe is possible on CTV pumps to allow emptying from a lower level. The liquid level can drop under the impeller (pump casing) during operation. However during startup the level must always be over the impeller (pump casing). See installation example, chapter 1.5.

Return flow

To avoid return flow, a check valve is recommended on the discharge side as near to the pumps as possible. It is of greatest importance in installations with high discharge height. See installation example, chapter 1.5.

1. INSTALLATION

1.5 Installation example

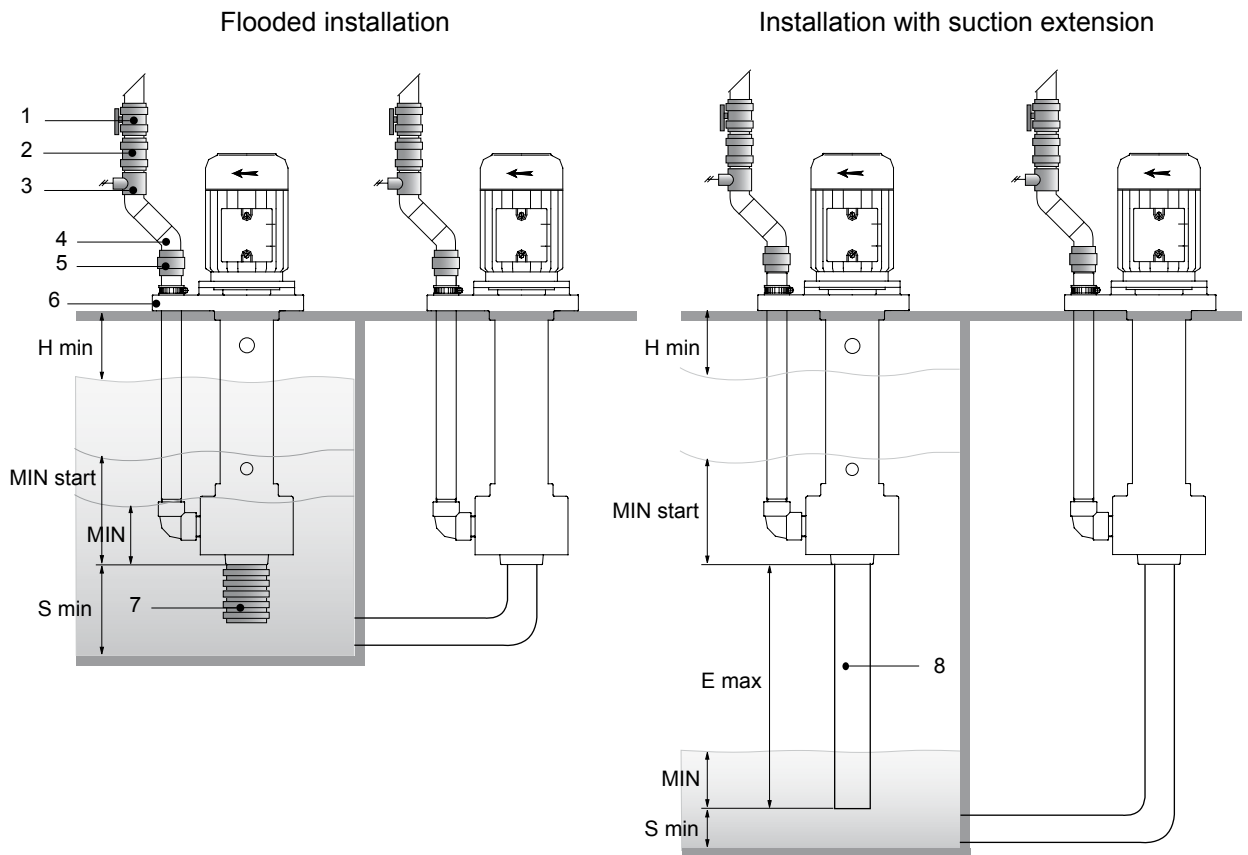

All installations

- 1) Valve for flow control (diaphragm valve or similar)
- 2) Non-return valve (check valve) on discharge side as near the pump as possible
- 3) Connection point for pressure gauge or pressure switch
- 4) Divert discharge with 45° bend to enable better space when lifting the pump
- 5) Quick connection between pump and pipe system for easy disconnection
- 6) Arrange for drainage of liquide from the base plate

Flooded installations

- 7) Foot strainer 3-5 mm mesh if solids are present or in open tank/sump installations

Installations with suction extension

- 8) Vertical suction extension allowed. Size of pipe shall correspond with connection size. No complex piping system on suction side. In particular applications, use of bottom valve (ball type) may be used, consult us.

Important levels and dimensions



	PP & PVDF pumps	stainless steel pumps	Comment
H min (mm / inch)	50 / 2.0	80 / 3.1	Minimum distance at max level
MIN start (mm / inch)	170 / 6.7	170 / 6.7	Min level during startup
MIN (mm / inch)	80 / 3.1	80 / 3.1	Min level during operation
S min (mm / inch)	50 / 2.0	50 / 2.0	Min distance to bottom of tank/sump
E max @ 25°C (mm / inch)	1000 / 39	1000 / 39	Max length suction extension
E max @ 40°C (mm / inch)	500 / 19	500 / 19	
E max @ 60°C (mm / inch)	-	-	Impeller must always be submerged

▶ 1. INSTALLATION

1.6 Instruments



In order to ensure a reasonable control of the performance and the conditions of the pump installed, we recommend using the following instruments:

- a pressure-vacuum gauge on the delivery piping.

The output can be read on the pressure, transformed into meters and then compared with the typical curves.

Electric power

The electric power absorbed by the motor can be measured with wattmeters.

Optional instruments

The optional instruments can advise of abnormal operating conditions of pumps, such as: valves closed accidentally, missing liquid, overloads, etc.



Thermometer

If the temperature of the pumped liquid can be a critical element, provide a thermometer.

1.7 Motor Connection



An expert electrician must always carry out the electrical connection. Compare the power supply with the data plate specifications and then choose a suitable connection. The type of connection is stated on the motor data plate that can be **Y** (star) or **D** (Delta), according to the power supply of the motor (see figure).

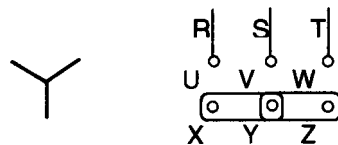

Star connection **Y**

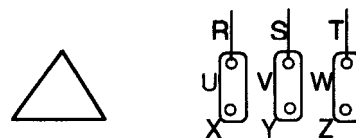

Delta connection **D**



Follow the prescriptions of the local electricity board for the connection. In no case connect the electrical motors directly to mains but also fit in between a suitable electric switchboard equipped with a knife switch and suitable safety devices. Safety devices against overloads must protect the motors. Make sure that the motor has suitable grounding and that it has been connected properly.

2. OPERATION

2.1 Start-up



- The motor shall be connected by qualified personnel only.
- Check manually that the motor is free to turn, moving the motor cooling fan.
- Make sure that the piping is not clogged and is free from residues or foreign objects.



- Bump start the motor to determine the direction of rotation (indicated with an arrow on the motor). If change is necessary, follow instruction in chapter 1.7.
- The shutoff/regulation valve on the discharge side must be almost completely closed at start-up.
- Any auxiliary connections must all be connected.

2.1.1 Starting the pump

- When ever starting the pump, the pump casing must be filled with liquid, see MIN start level in chapter 1.5.



- Start the electric motor and open the discharge adjustment/shutoff valve gradually until the desired output has been reached. The pump must not turn more than two or three minutes with discharge closed. A longer operation in these conditions can damage the pump.



- If the pressure shown on the pressure gauge on the discharge piping does not increase, turn off the pump immediately and release pressure carefully. Repeat the connection procedure.



- If there are changes of flow-rate, head, density, temperature or viscosity of the liquid, stop the pump and get in touch with our technical service.



- During operation, make sure the liquid level is within the limits, see levels H min and MIN in chapter 1.5.

2.1.2 Re-starting after power shutoff

In case of accidental stopping, make sure that the non-return valve has prevented backflow and check that the motor cooling fan has stopped. Start the pump again following the instructions of chapter 2.1.1 "Starting the pump".

2.2 Stopping the Pump



It is advisable to close the discharge adjustment/shutoff valve gradually and stop the motor immediately after. The reverse sequence is not recommendable, especially with larger pumps or longer delivery piping. That is to avoid any problems due to water hammering.

▶ 3. MAINTENANCE



Maintenance work on electrical installations must be performed by qualified personnel and only when the power supply has been shutdown. Follow the local and national safety regulations.

3.1 Maintenance schedule

The CTV range pumps generally do not require any maintenance. However depending on the application, it may be necessary to once in a while clean the internals of the pump to optimize the performance.

3.2 Trouble shooting

Problem	Possible fault	Measure to take
Failure to deliver	Liquid level too low Motor speed too low Impeller clogged Wrong direction of rotation NPSHa too low	See MIN start level chapter 1.5 Check the motor and motor connection Clean the pump See chapter 1.7 for change of direction Consult us
Insufficient capacity	Head higher than expected Impeller or discharge clogged Impeller damaged Wrong direction of rotation	Check piping system Clean the pump internally Change impeller See chapter 1.7 for change of direction
Insufficient head	Air in the casing or discharge Motor speed too low Impeller damaged Impeller diameter too small	Check system for air pockets Check the motor and motor connection Change impeller Consult us for eventual change
Irregular flow	Liquid level too low Suction or strainer clogged	See MIN liquid level chapter 1.5 Check and clean
Electric current too high (motor protection shut)	Specific gravity higher than expected Viscosity higher than expected Head lower than expected Motor bearings worn	Increase the head with flow control valve Consult us Increase the head with flow control valve Change bearings, check vapour seal
Pump vibrates	Pump insufficiently fastened Impeller damaged or clogged Motor bearings worn Liquid level too low	Check the pump mounting bolts Check and clean or replace impeller Change bearings, check vapour seal See MIN liquid level chapter 1.5

3. MAINTENANCE

3.3 Assembly and disassembly



The assembly and disassembly should only be performed by qualified personnel. While working on the pump protective clothing such as eye glasses and gloves should be worn.



Each operation carried out on the machine must always be carried out once all the electrical contacts have been disconnected. The pump-motor unit must be placed in a position where it cannot be started unintentionally.



Before servicing in any way the parts in contact with the pumped liquid, make sure that the pump has been fully emptied and washed. When draining the liquid, make sure that there is no danger for people or the environment.

3.3.1 Assembly drawings

PP & PVDF pumps

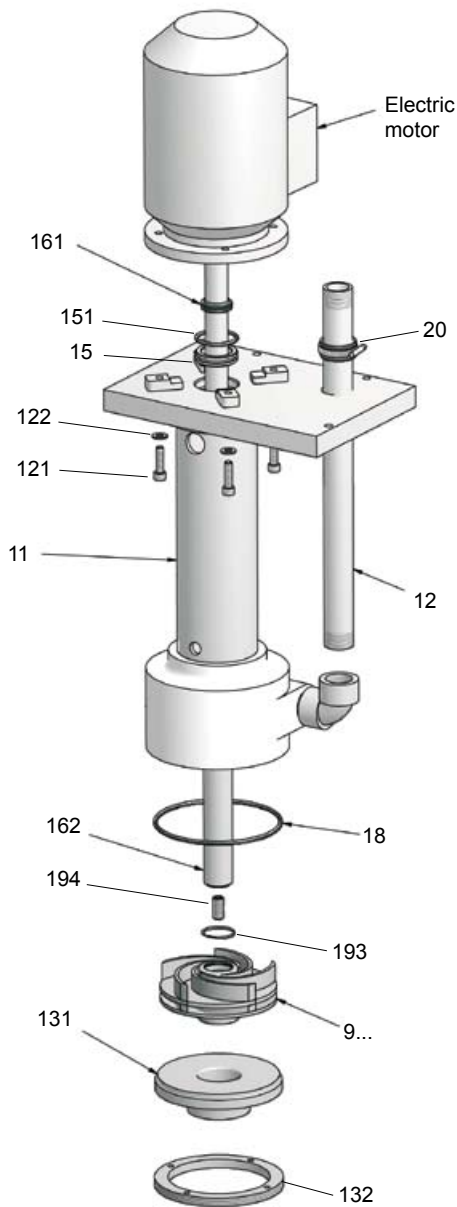

Stainless steel pumps

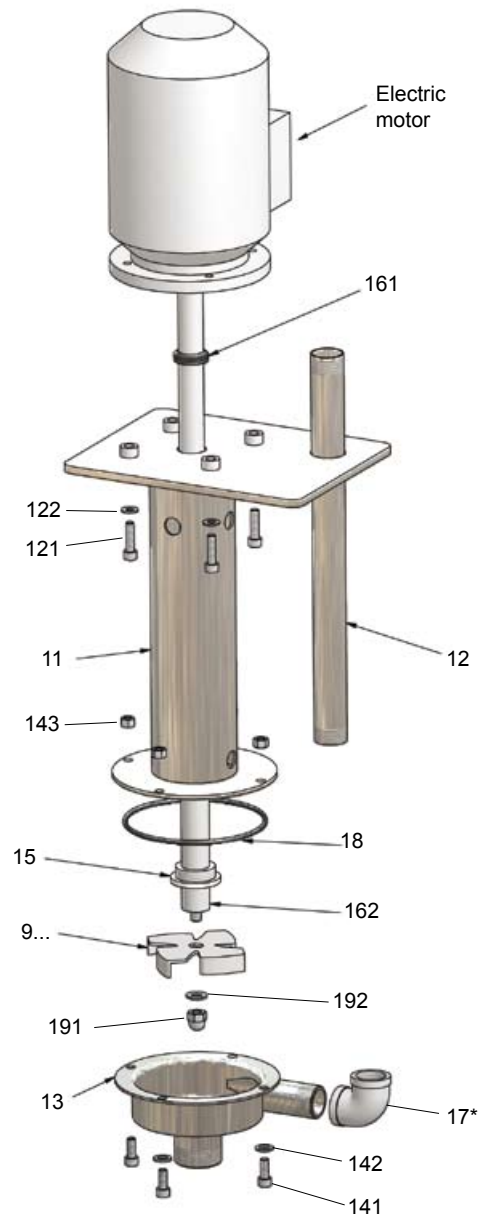

* = On CTV 40, pos 17 is welded on pos 13

▶ 3. MAINTENANCE

3.3.2 Dismantling PP & PVDF pumps

- After removal of eventual suction extension or strainer, place the pump horizontally on a bench.
- Unscrew counterclockwise the lock ring (132) by inserting suitable tool in the holes.
- Remove the pump cover (131), if necessary screw a plastic nipple into the pump cover and then pull.
- Remove the motor fan cover from the electric motor and then remove the motor fan.
- Secure the free end of the motor shaft by means of a universal pliers or similar.
- Insert two screw drivers cross wise into the impeller opening (9...) and unscrew the impeller (9...) counterclockwise.
- Remove the impeller o-ring (193) from the impeller.
- Unscrew the motor mounting screws and washers (121 and 122) and carefully pull the pump casing unit (13) from the motor/shaft assembly.
- Pull the shaft sleeve (162) from the motor shaft and then pull off the lip seal (161).
- Carefully hammer out the shaft bushing (15) from its seat by means of a soft driver (plastic). Remove the o-ring (151) from the shaft bushing.
- Loosen the hose clip (20) and remove the stabilizer from the discharge pipe.

3.3.3 Dismantling stainless steel pumps

- After removal of eventual suction extension or strainer, place the pump horizontally on a bench.
- Unscrew the casing mounting screws with washers (141 and 142) and lift carefully off the pump cover together with elbow and discharge pipe (13, 17 and 12).
- Secure the impeller by putting a screwdriver through the open impeller blades, unscrew the impeller nut and washer (191 and 192), lift off the impeller (9...).
- Unscrew the shaft bushing (15) from the pump casing unit (11).
- Unscrew the motor mounting screws and washers (121 and 122) and carefully pull the pump casing unit (13) from the motor/shaft assembly.
- Remove the motor fan cover from the electric motor and then remove the motor fan.
- Secure the free end of the motor shaft by means of a universal pliers or similar. Unscrew the shaft sleeve (162) from the motor shaft and then pull off the lip seal (161).

3.3.4 Parts inspection

After the dismantling, check all parts for wear or damage and replace if necessary. O-rings are always recommended to replace after dismantling.

3.3.5 Assembly of the pump - PP, PVDF and stainless steel pumps

Assemble the pump in reverse order to dismantling. When mounting the pump casing unit (11) to the motor, make sure the shaft rotates concentrically in the casing unit.

Install and startup the pump according to instructions in chapter 2.

▶ 4. SPARE PARTS

4.1 Spare parts CTV pumps in PP & PVDF

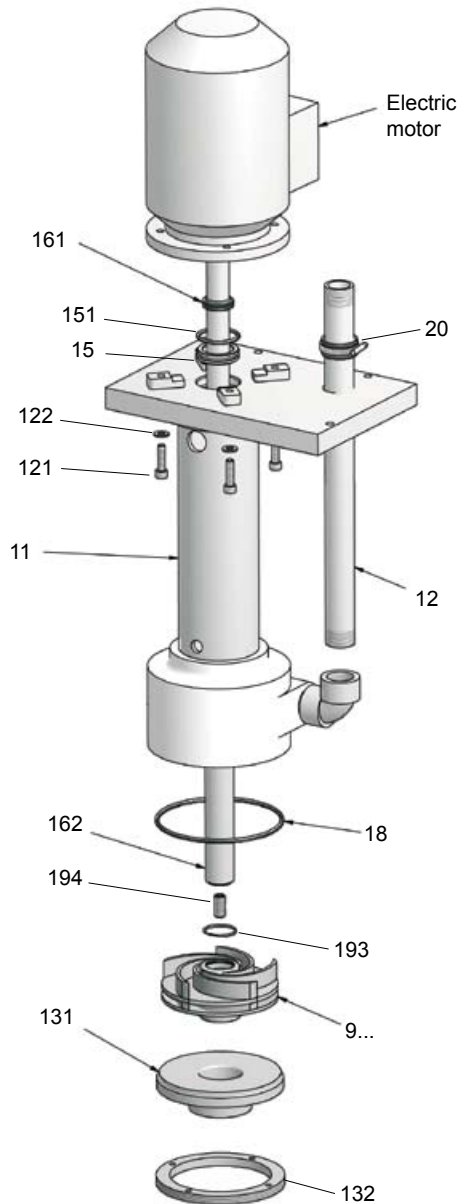

Pos	Description	Qty/ pump	Material
11	Pump casing unit	1	PP or PVDF
12	Discharge pipe	1	PP or PVDF
121	Motor mounting screw	4	Stainless steel
122	Motor mounting washer	4	Stainless steel
131	Pump cover	1	PP or PVDF
132	Lock ring	1	PP or PVDF
15	Shaft bushing	1	Ceramic
151	Shaft bushing o-ring	1	NBR
161	Lip seal	1	NBR or FKM
162	Shaft sleeve	1	PP or PVDF
17	Elbow	1	PP or PVDF
18	Casing o-ring	1	EPDM, FKM or FEP
193	Impeller o-ring	1	EPDM, FKM or FEP
194	Impeller screw	1	Stainless steel
20	Hose clip	1	PP + stainless steel
9085	Impeller CTV 32-8.5	1	PP or PVDF
9090	Impeller CTV 25-9	1	PP or PVDF
9100	Impeller CTV 25-10 and CTV 32-10	1	PP or PVDF
9111	Impeller CTV 25-11	1	PP or PVDF
9115	Impeller CTV 25-11.5	1	PP or PVDF
9125	Impeller CTV 32-12.5	1	PP or PVDF

4. SPARE PARTS

4.2 Spare parts CTV pumps in stainless steel

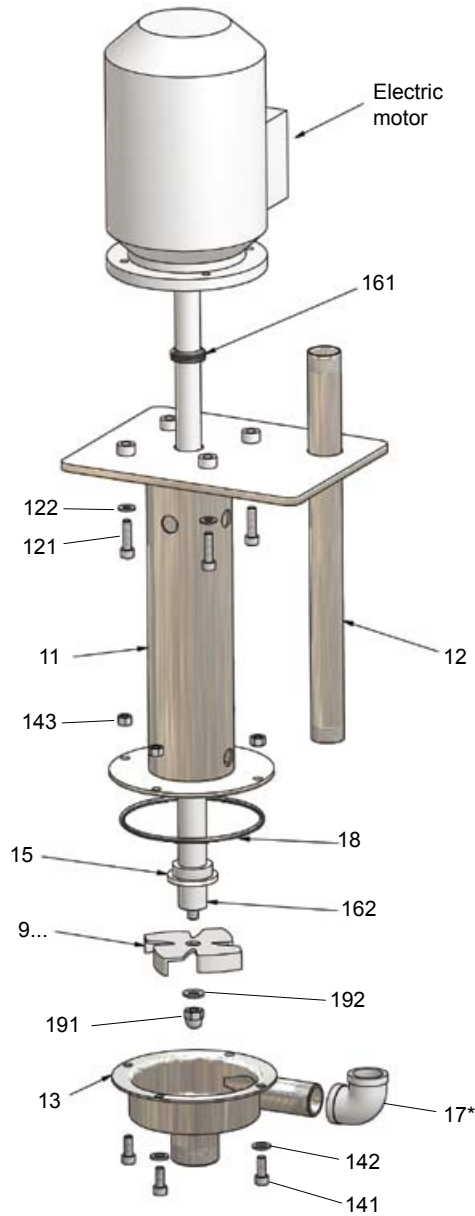

Pos	Description	Qty/ pump	Material
11	Pump casing unit	1	AISI 316L
12	Discharge pipe	1	AISI 316L
121	Motor mounting screw	4	Stainless steel
122	Motor mounting washer	4	Stainless steel
13	Pump cover	1	AISI 316L
141	Casing mounting screw	4	Stainless steel
142	Casing mounting washer	4	Stainless steel
143	Casing mounting nut	4	Stainless steel
15	Shaft bushing	1	PTFE
161	Lip seal	1	NBR or FKM
162	Shaft sleeve	1	AISI 316L
17*	Elbow	1	AISI 316L
18	Casing o-ring	1	EPDM, FKM or FEP
191	Impeller mounting screw	1	AISI 316L
192	Impeller mounting washer	1	AISI 316L
9090	Impeller CTV 20-9	1	AISI 316L
9098	Impeller CTV 25-9.8	1	AISI 316L
9125	Impeller CTV 40-12.5	1	AISI 316L
9135	Impeller CTV 40-13.5	1	AISI 316L

* = On CTV 40, pos 17 is welded on pos 13

4. SPARE PARTS

4.3 Stocking recommendation

Depending on the nature of the liquid and temperature etc, some parts of the pump are subject to wear and have to be replaced. We recommend having the following parts in stock:

PP & PVDF pumps

Pos	Description	Qty
161	Lip seal	1
193	Impeller o-ring	1
18	Casing o-ring	1
132	Lock ring	1

Stainless steel pumps

Pos	Description	Qty
161	Lip seal	1
15	Shaft bushing	1
18	Casing o-ring	1

4.4 Pump code

The model number on the pump tells the pump size and material of the pump

CTV vertical centrifugal pump

Pump size (Outlet mm - impeller mm)

PP & PVDF pumps:

CTV 25-9
CTV 25-10
CTV 25-11
CTV 25-11.5
CTV 32-8.5
CTV 32-10
CTV 32-12.5

stainless steel pumps:

CTV 20-9
CTV 25-9.8
CTV 40-12.5
CTV 40-13.5

Motor power

05 = 0.55 kW (CTV 25-9, 20-9)
07 = 0.75 kW (CTV 25-10, 25-9.8)
11 = 1.1 kW (CTV 25-11, 32-8.5, 25-9.8)
15 = 1.5 kW (CTV 25-11.5, 32-10, 40-12.5)
22 = 2.2 kW (CTV 32-12.5, 40-13.5)

CTV - **25-10** - **P** - **2V** - **07**

Material pump housing

P = PP (polypropylene)
K = PVDF (polyvinylidene fluoride)
S = Stainless steel AISI 316L

Special options

2 = Casing o-ring
blank* = EPDM
V = FKM
F = FEP/silicone

3 = Lip seal (vapour seal at motor)
blank* = NBR
V = FKM

4 = Suction extension pipe (same material as pump)
E05 = Suction extension 0.5 m
E10 = Suction extension 1.0 m

5 = Optional connection discharge
blank* = BSP thread
A = ANSI flange
D = DIN flange

* = Standard execution

Changes reserved without notice

5. DATA

5.1 Performance curves

The performance curves are based on water at 20°C. Speed 2900 rpm.
Contact us for detailed curves.

5.1.1 Performance curves PP & PVDF pumps

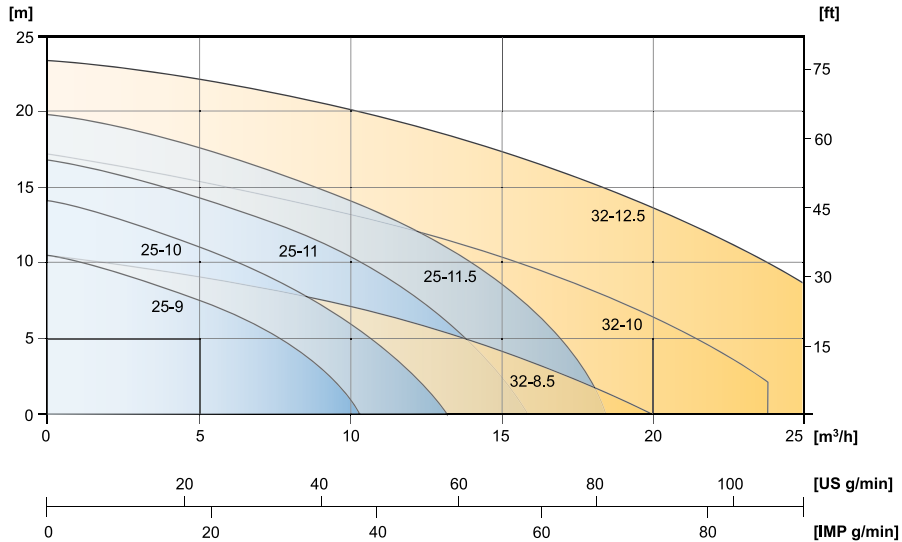

5.1.2 Performance curves stainless steel pumps

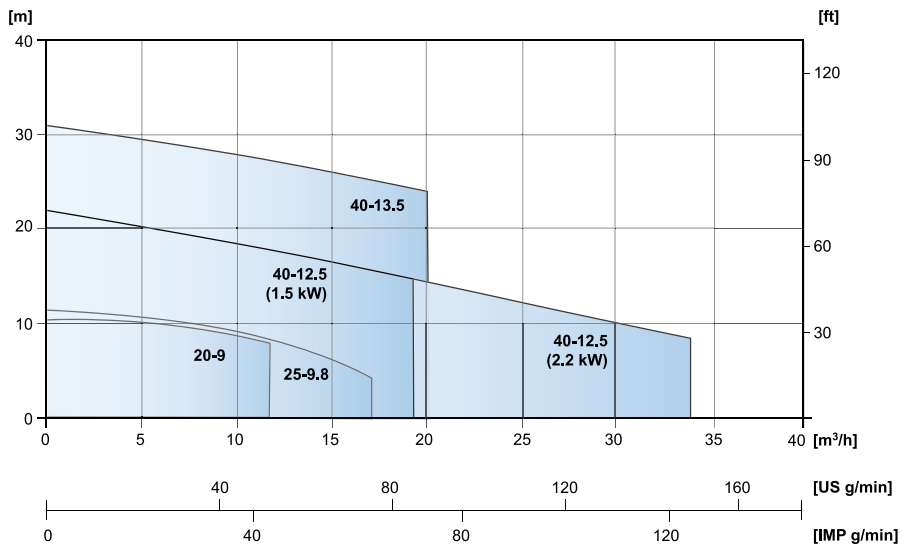

Changes reserved without notice

5. DATA

5.2 Technical data

5.2.1 Data PP & PVDF pumps

Dimensions in mm, where other is not indicated

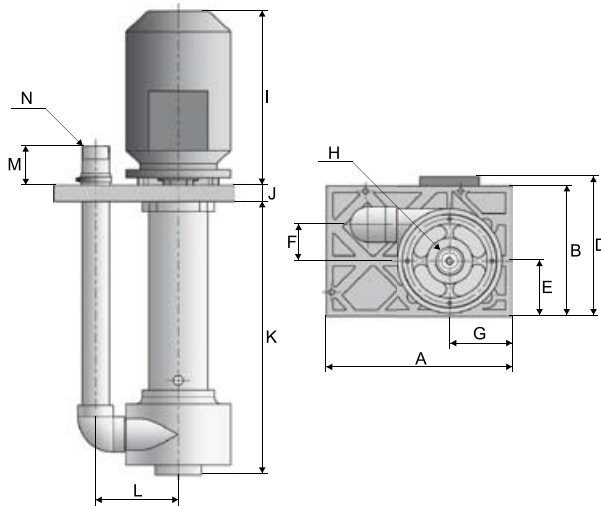

Dimension	CTV 25	CTV 32
A	285	285
B	200	200
E	85	85
F	56	56
G	95	95
H	1"	1 1/4"
J	25	25
K	419	419
L	123	126
M	60	60
N	1"	1 1/4"
Motor power	D	I
0.55 kW	196	213
0.75-2.2 kW	214	267

General characteristics	25-9	25-10	25-11	25-11.5	32-8.5	32-10	32-12.5
Max capacity (m ³ /h)	10.2	13.2	15.6	18.0	19.8	24.0	27.0
Max head (m)	10	14	16	19	10	17	23
Motor power (kW)	0.55	0.75	1.1	1.5	1.1	1.5	2.2
Outlet dimension (male BSP)	1"	1"	1"	1"	1 1/4"	1 1/4"	1 1/4"
Motor data	3-phase, 2-pole (~2900 rpm), 380-420 VAC, 50 Hz, IP 55						
Max temperature	Pump in PP: 70°C, pump in PVDF: 100°C						
Materials							
Pump casing and impeller	PP or PVDF						
Casing o-ring	EPDM, FKM or FEP						

Changes reserved without notice

5. DATA

5.2.2 Data stainless steel pumps

Dimensions in mm, where other is not indicated

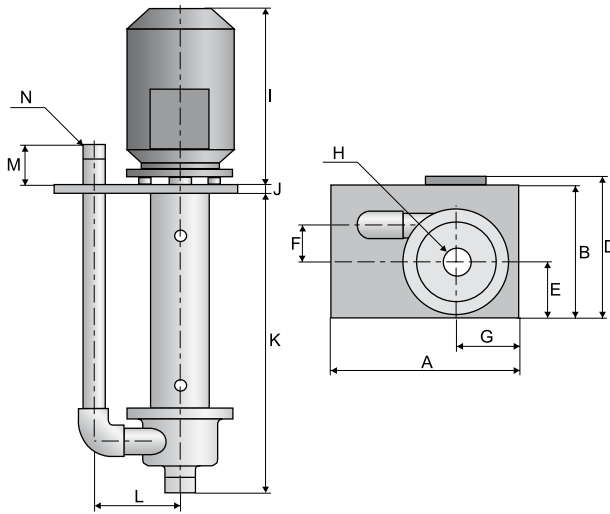

Dimension	CTV 20	CTV 25	CTV 40
A	267	267	267
B	207	207	207
E	102.6	102.6	102.6
F	36	50	66
G	93.5	93.5	93.5
H	1"	1 1/2"	1 1/2"
J	8	8	8
K	420.5	420.5	425
L	113.5	127	139
M	60	60	60
N	3/4"	1"	1 1/2"
Motor power	D	I	
0.55 kW	214	211	
0.75-2.2 kW	253	265	

General characteristics	20-9	25-9.8	25-9.8	40-12.5	40-12.5	40-13.5
Max capacity (m ³ /h)	12.0	17.0	17.0	19	34	20
Max head (m)	10	11	11	22	22	31
Motor power (kW)	0.55	0.75	1.1	1.5	2.2	2.2
Outlet dimension (male BSP)	3/4"	1"	1"	1 1/2"	1 1/2"	1 1/2"
Motor data	3-phase, 2-pole (~2900 rpm), 380-420 VAC, 50 Hz, IP 55					
Max temperature	100°C					
Materials						
Pump casing and impeller	Stainless steel AISI 316L					
Casing o-ring	EPDM, FKM or FEP					

Changes reserved without notice

▶ 6. WARRANTY & REPAIR

6.1 Returning parts

When returning parts to Tapflo AB please follow this procedure:

- Consult Tapflo AB for shipping instructions.
- Cleanse or neutralize and rinse the part/pump. Make sure the part/pump is completely empty from liquid.
- Pack the return articles carefully to prevent any damage under transport.

Goods will not be accepted unless the above procedure has been complied with.

6.2 Warranty

Tapflo warrants products under conditions as below for a period of not more than 12 months from installation and not more than 24 months from date of manufacture.

1. The following terms and condition apply to the sale of machinery, components and related services and products, of Tapflo (hereinafter “the products”)
2. Tapflo (the manufacturer) warrants that:
 - a.) its products as being free of defects in material, design and workmanship at the time of original purchase;
 - b.) its products will function in accordance with Tapflo operative manuals; Tapflo does not guarantee that the product will meet the precise needs of the Customer, except for those purposes set out in any invitation to render documents or other documents specifically made available to Tapflo before entering into this agreement;
 - c.) high quality materials are used in the construction of the pumps and that machining and assembly are carried out to the highest standards.

Except as expressly stated above, Tapflo makes no warranties, express or implied, concerning the products, including all warranties of fitness for a particular purpose.

3. This warranty shall not be applicable in circumstances other than defects in material, design, and workmanship. In particular warranty shall not cover the following:
 - a.) Periodic checks, maintenance, repair and replacement of parts due to normal wear and tear (seals, O-rings, rubber items, bushings, etc..);
 - b.) Damage to the product resulting from:
 - b.1.) Tampering with, abuse or misuse, including but not limited to failure to use the product for its normal purposes as stated at the time of purchase or in accordance with Tapflo instructions for use and maintenance of the product, or the installation or improper ventilation or use of the product in a manner inconsistent with the technical or safety standard in force;
 - b.2.) Repairs performed by non skilled personell or use of non original Tapflo parts
 - b.3.) Accidents or any cause beyond the control of Tapflo, including but not limited to lightning, water, fire, earthquake, and public disturbances, etc.;
4. The warrantee shall cover the replacement or repairing of any parts, which is documentedly faulty due to construction or assembling, with new or repaired parts free of charges delivered by Tapflo. Parts subjected to normal tear and wear shall not be covered by the warranty. Tapflo shall decide as to whether the defective or faulty part shall be replaced or repaired.
5. The warrantee of the products shall be valid for a period in accordance to the current law from the date of delivery, under the condition that notice of the alleged defect to the products or parts thereof be given to Tapflo in written within the mandatory term of 8 days from the discovery.

6. WARRANTY & REPAIR

- 6 Repair or replacement under the terms of this warranty shall not give a right to an extension to, or a new commencement of, the period of warranty. Repair or replacement under the terms of this warranty may be fulfilled with functionally equivalent reconditioned units. Tapflo qualified personnel shall be solely entitled to carry out repair or replacement of faulty parts after careful examination of the pump. Replaced faulty parts or components will become the property of Tapflo
- 7 The products are built in accordance with standard CE normative and are tested (where applicable) by Tapflo. Approval and tests by other control authority are for the customers account. The products shall not be considered defective in materials, design or workmanship if they need to be adapted, changed or adjusted to conform to national or local technical or safety standards in force in any country other than that for which the unit was originally designed and manufactured. This warranty shall not reimburse such adaptations, changes or adjustments, or attempt to do so, whether properly performed or not, nor any damage resulting from them, nor any adaptation, change or adjustments to upgrade the products from their normal purpose as described in the products operative manual without the prior written consent of Tapflo
- 8 Installation, including electric and other connections to utility mains according to Tapflo drawings, is for the cost and responsibility of the customer, unless otherwise agreed in writing.
- 9 Tapflo will not be liable on any claim, whether in contract, tort, or otherwise, for any indirect, special, incidental, or consequential damages, caused to the customer or to third parties, including loss of profits, arising by any possible infringement of par. 3 above or by the customer or third parties being in the impossibility of using the products.

Steady the above, Tapflo liability to the customer or third parties from any claim, whether in contract, tort, or otherwise, shall be limited to the total amount paid by the customer for the product that caused the damages.

A large grid of graph paper for taking notes, consisting of 20 columns and 30 rows of small squares.



Tapflo AB · Filaregatan 4 · S-442 34 Kungälv · Sweden
Tel (46) 303 63390 · Fax (46) 303 19916 · E-mail: sales@tapflo.com · www.tapflo.com

DISTRIBUTOR: