

TECHNICAL DATASHEET - LPX80-1

topflo®



EHEDG compliant

Product images are for illustrative purposes only and may differ from the actual product.
Certificates may vary depending on the material execution of a particular product.

Materials, data and limits

Technical DATA	LPX80-1
Casing Material	Stainless Steel EN 10088-3/1.4404
Rotor Material	Stainless Steel EN 10088-3/1.4404
Shaft Material	Stainless Steel EN 10088-3/1.4404
Front Cover	Stainless Steel EN 10088-3/1.4404
Displacement [l/rev]	0.94
Connection size	75 (3")
Differential pressure rating [bar/]	10
Maximum pumps speed [rpm]	700
Input shaft diameter [mm/]	38
Maximum torque [N-M]	400
Fittings Type	DIN 11851 Thread (Default)
Rotors Type	Trilobe In Stainless Steel
Shaft Seal	single mechanical seal SiC/SiC FDA (Default) options: double mechanical seal SiC/SiC FDA
O-ring Material	FKM FDA (Default) options: EPDM FDA
Shaft Position	horizontal: Shaft Top
Front Cover	standard or with a heating jacket
Paint	RAL 9010 - white
Documentation	
Seal Certification	FDA approved
Design	3A certified & conform EC 1935/2004



General performance curve

The performance curves are based on 500cP liquid.

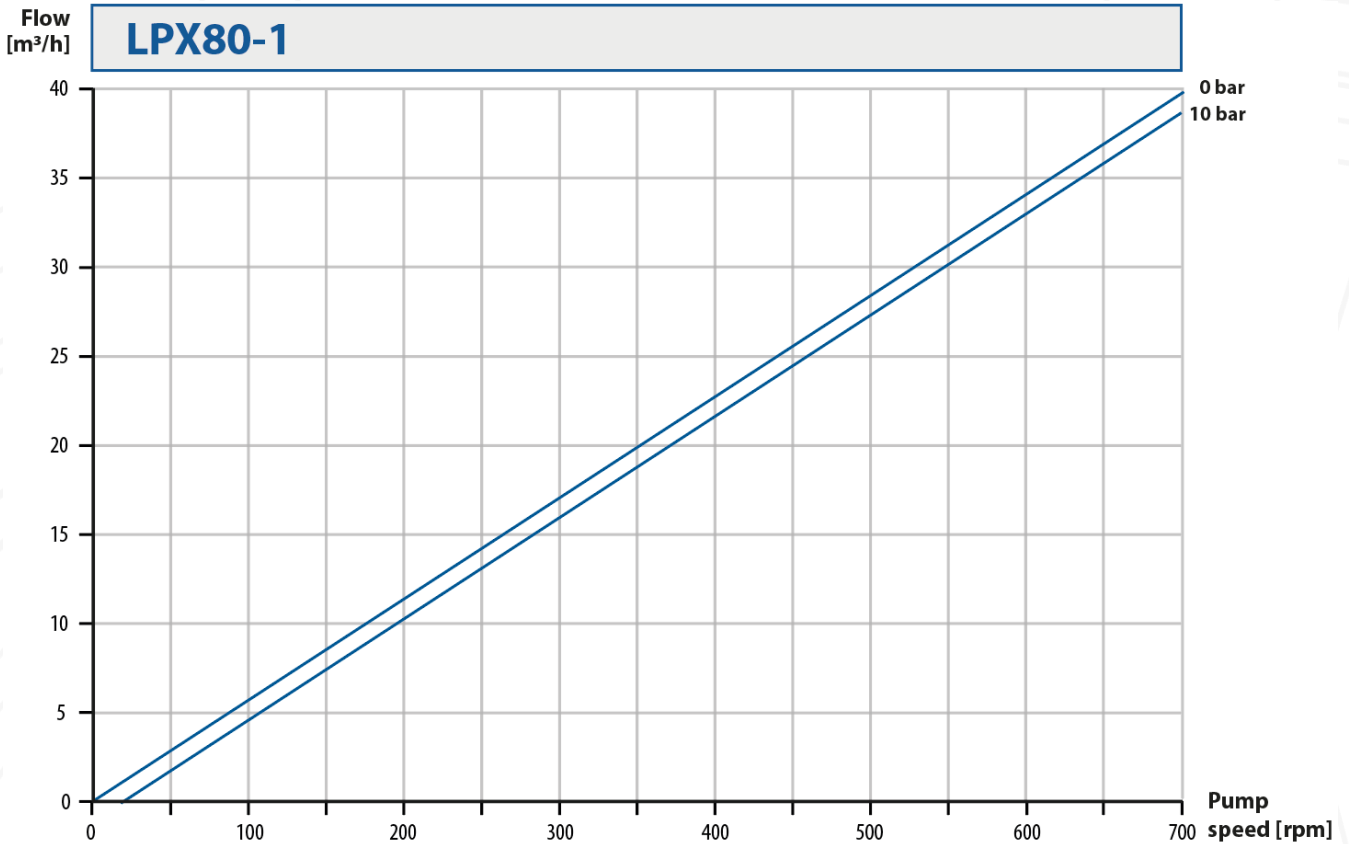

Overall pump dimensions

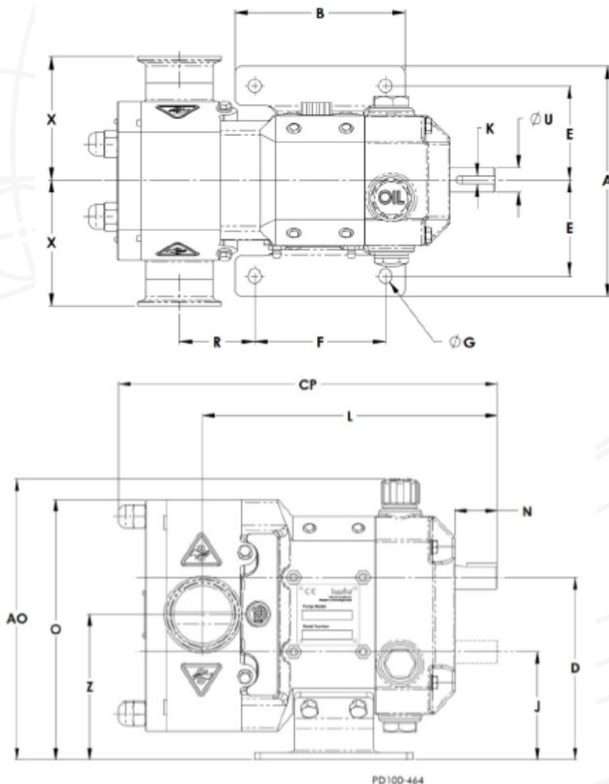

Dim	[mm]
A	239.1
AO	310.6
B	160.0
CP	423.9
D	205.9
E	99.5
F	120.0
G	13
J	112.9
K	10x8
L	332.6
N	57.6
O	292.9
R	87.1
U	38
X	134.0
Z	159.4

