

Drainage pumps

Pumps for complete drainage of flat surfaces where sump is not available. For example rooftops, parking lots, facilities and cellars

SG series

SG has a smart design bottom plate that enables the pump to operate and drain down to 1 mm water level. The pump is equipped with a swing valve that prevents reverse flow from discharge hose when the pump is shut-off. A rubber stand protects the floor and ground surfaces from any scratches.

Waters cooling route to the top outlet, allows the pump to operate for extended periods while pumping small amounts of water.

The discharge direction can be mounted either vertical or inclined, which prevents folding or bending of the discharge hose.

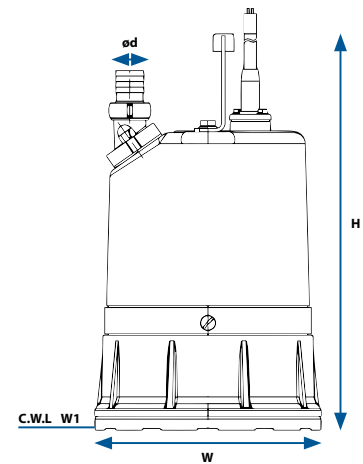

Fast facts

Capacity:	14 m ³ /h
Head:	11.5 m
Power:	0.48 kW, single-phase 230 V ± 10 %, 50 Hz
Insulation class:	F
Protection class:	IP 68
Outlet:	25 mm
Water temperature:	Up to 40 °C
Max water depth:	10 m
Cable length:	8 m

Technical data

Model (50 Hz)	Height (H)	Width (W)	Weight (net)	Outlet (ød)	Continuous running water level (W1)
	mm	mm	Kg	mm	mm
SG2-04	358	205	12.6	25	1

Model (50 Hz)	Motor power	Voltage	Rated Capacity		Rated head	Max capacity		Max head	Impeller Passage	Max depth
	kW	V	m ³ /h	l/min	m	m ³ /h	l/min	m	mm	m
SG2-04	0.48	230	7	116	7	13	216	11.5	6	10

Performance curves - 50 Hz, 2850 rpm

